



International Beams
240 S Pineapple Avenue, Suite 510
Sarasota, FL, USA, 34236
Phone: (941) 552-9914

Technical Bulletin (TB-IJ-2)

Subject: Outrigger Overhang Framing at International Beams I-joists

April 2013 (Updated June 2017)

This technical bulletin is intended for use with International Beams Inc. products and offers general guidelines for topics that may not be covered in our literature. Appropriateness of details for a specific project should be evaluated by a qualified designer. This technical bulletin may be periodically updated. Check internationalbeams.com to ensure that you have the most recent version.

Architectural detailing at roof cornices can be done in many different ways. This is often an element of design that is not treated as a structural element. Typically, when roof overhangs are 24" or less, the structural impact of field-framed overhangs at I-joists is not significant. However, carpenters need some guidance to avoid damage to the I-joists that might occur if framing were done improperly. The following details illustrate two possible field framing methods that are not included in our International Beams literature.

Design / installation considerations:

- When a bevelled plate is used at the top of the exterior wall, the I-joist may be plumb cut at the outside face of the bearing and it will have bearing for the full width of the plate. The building designer should specify the attachment of the bevelled plate to the top of the bearing wall.
- When the I-joist has a horizontal seat cut, care must be taken that the seat cut does not overhang the inside face of the bearing. The horizontal seat cut at the bottom flange need not extend the full width of the bearing, but it must NOT overhang the inside face of the bearing.
- Web stiffeners are required for both of the conditions illustrated.
- Tie-down anchorage requirements must be specified by the building designer. Hurricane clips should be long enough so that nails will engage the web stiffeners in addition to the bottom flange of the I-joist.

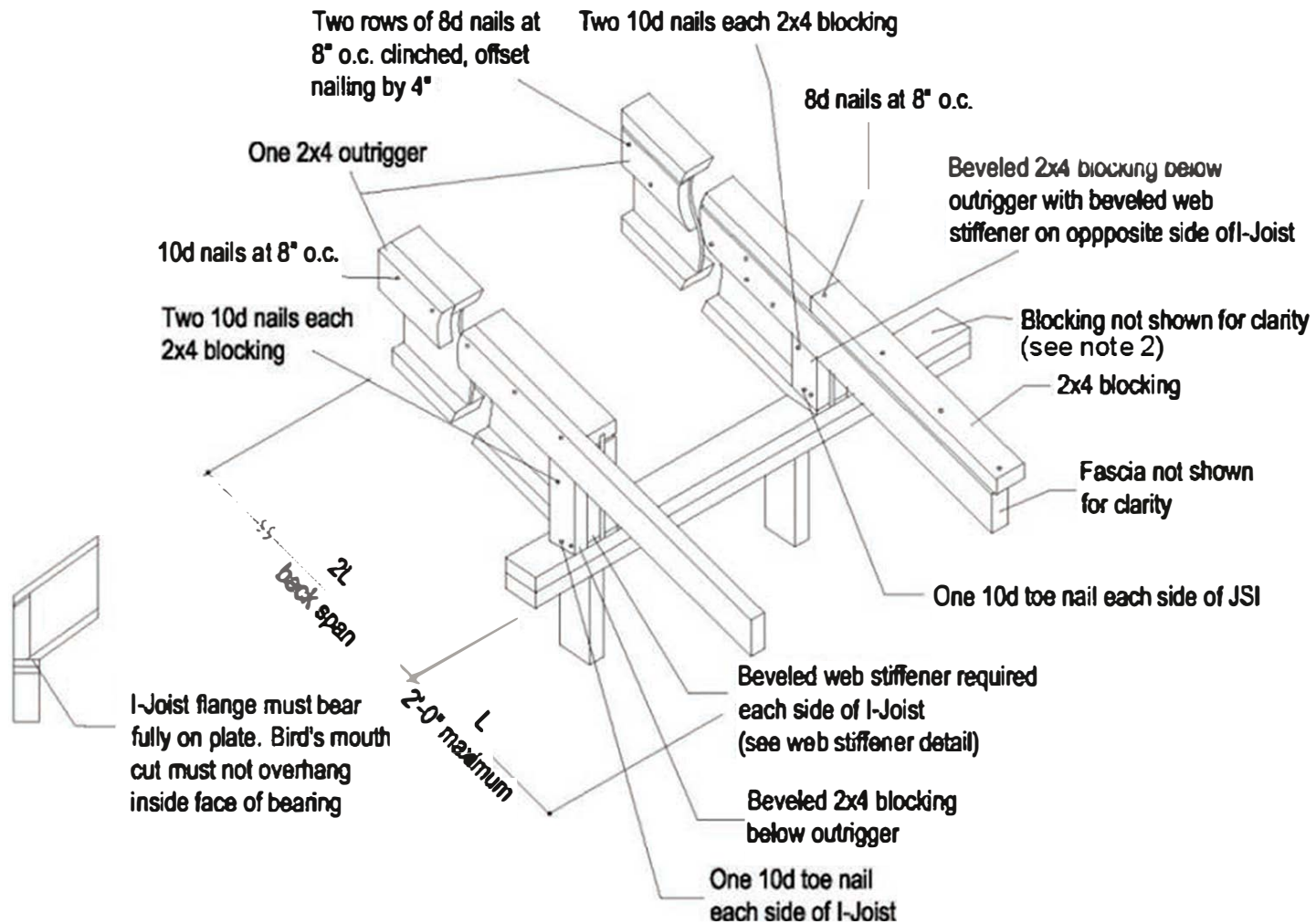

Notes:

1. This detail should be reviewed for applicability by the building designer. In cold climates, icicle load should be considered.
2. Lateral stability must be provided at the end of the I-joists with cross-bridging, full-depth blocking panels, or other suitable method. Design for global lateral stability is the responsibility of the building designer.
3. I-joists must be properly tied down for uplift. Straps for tie-down anchors should be long enough so that nails engage the web stiffeners. Design of this anchorage is the responsibility of the building designer.
4. Indicated nails are box nails or equivalent:
 8d, minimum 0.113" diameter x 2 1/2" long
 10d, minimum 0.128" diameter x 3" long

(TB3) OUTRIGGER O.H. FRAMING AT IB I-JOISTS, DETAIL B
HORIZONTAL SEAT CUT

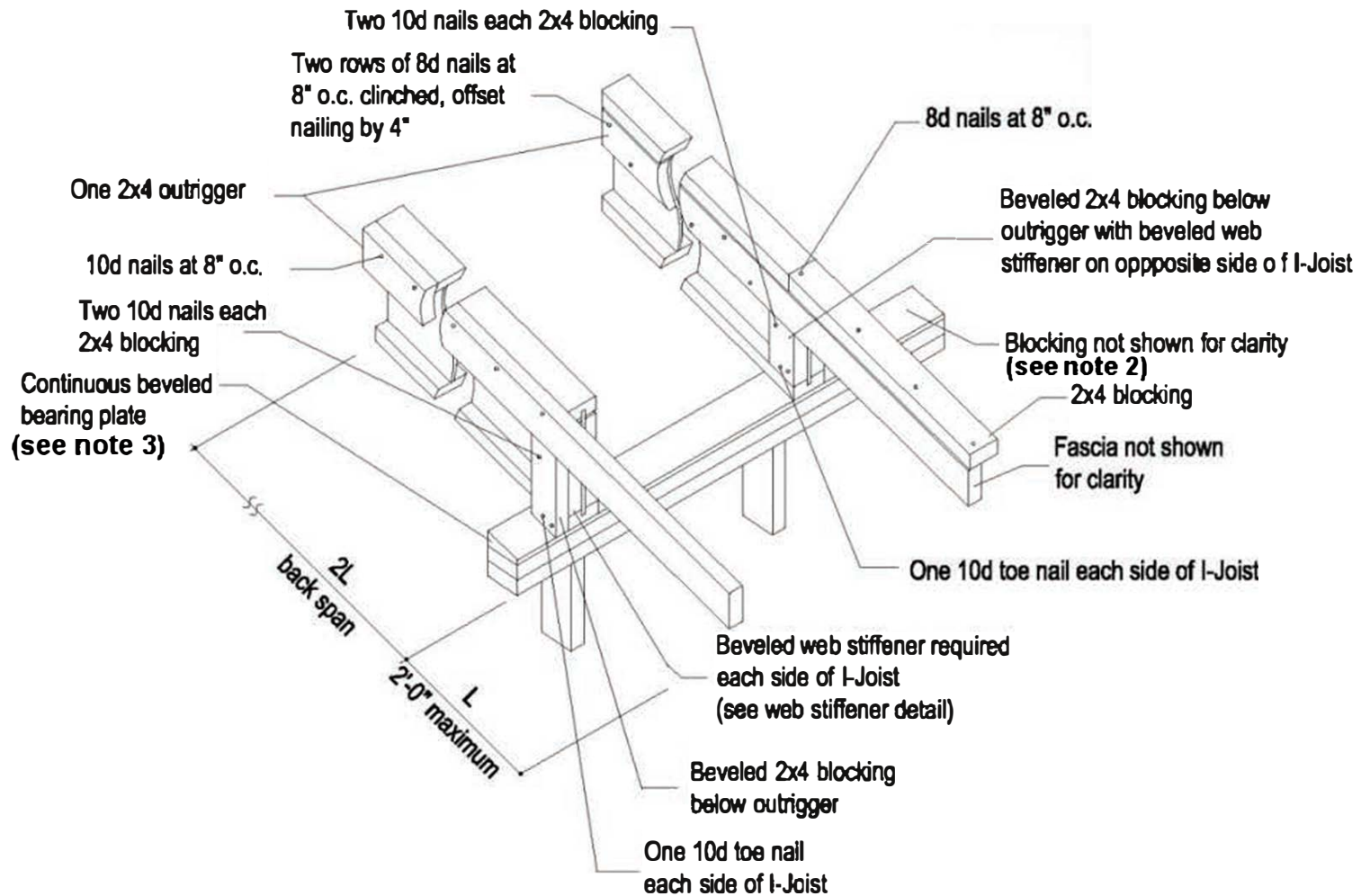

Notes:

1. This detail should be reviewed for applicability by the building designer. In cold climates, icicle load should be considered.
2. Lateral stability must be provided at the end of the I-joists with cross-bridging, full-depth blocking panels, or other suitable method. Design for global lateral stability is the responsibility of the building designer.
3. I-joists must be properly tied down for uplift. Straps for tie-down anchors should be long enough so that nails engage the web stiffeners. Beveled bearing plates shall be suitably anchored to the top of the wall. Design of this anchorage is the responsibility of the building designer.
4. Indicated nails are box nails or equivalent:
 8d, minimum 0.113" diameter x 2 1/2" long
 10d, minimum 0.128" diameter x 3" long

(TB3) OUTRIGGER O.H. FRAMING AT IB I-JOISTS, DETAIL A
BEVELED BEARING PLATE